

Swing Door

ASSA ABLOY SW200i™

ASSA ABLOY

ASSA ABLOY Entrance Systems

The global leader in
door opening solutions

Technical Data Sheet

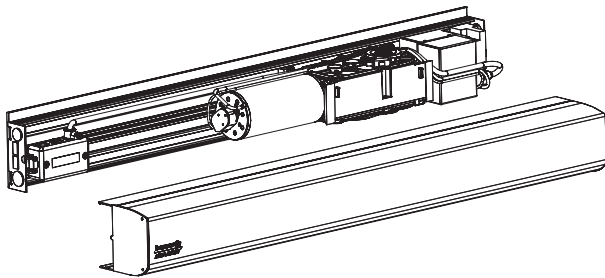

SW200i Swing Door Operator

The ASSA ABLOY SW200i automatic swing operator is intended for use in exterior or interior entryways, corridors and a variety of applications. The ASSA ABLOY SW200i heavy duty (HD) electro-mechanical operator is suitable for use on large heavy doors, yet adaptable enough to be used in low energy (LE) applications. The product can be either surface mounted or overhead concealed, on either side of the door, for pull or push applications. It is suitable for single doors, double doors and double egress doors fitted with swing clear hinges, offset pivots or center pivots. The operator is connected to the door leaf with a range of different arm systems.

ASSA ABLOY SW200i is designed to offer continuous use, a high degree of safety and maximum performance over the lifetime of your entrance. The ASSA ABLOY SW200i ensures all-around safety and can be equipped with a full range of sensor products providing swing door safety that meets or exceeds ANSI A156.10 standard.

Operator Features and Performance

- Operator: electro-mechanical, non-handed operator, 24 volt, 5/16 hp motor
- ANSI Compliance: Field selectable full pedestrian usage (ANSI A156.10) and low energy (ANSI A156.19)
- Door Weight: up to 700 pounds (315 kg) per operator
- Door Size: up to 48" (consult for wider sizes)
- Manual Push Force: adjustable from 5 lbf – 15 lbf
- Hold Open Time: adjustable from 1.5 seconds to 30 seconds
- Wind Force Dampening: operator mechanically counteracts to wind forces, slowing down the opening or closing of the door
- Stack Pressure Compensation: operator counteracts to positive stack pressures, negative stack pressures, and sudden changes of stack pressures to maintain consistent door speeds
- Intelligent Trajectory Control: operator knows where the door should be at all times and adjusts torque accordingly. Dynamic braking helps cushion the door during opening to prevent going past 90 degrees, or during closing to prevent slamming.
- Extended Closing Torque (ECT): exclusive Extended Closing Torque (ECT) functionality provides extra torque in the last 10 degrees of closing, if needed, to close and latch the door. Speed remains constant so the door stays within ANSI standards.

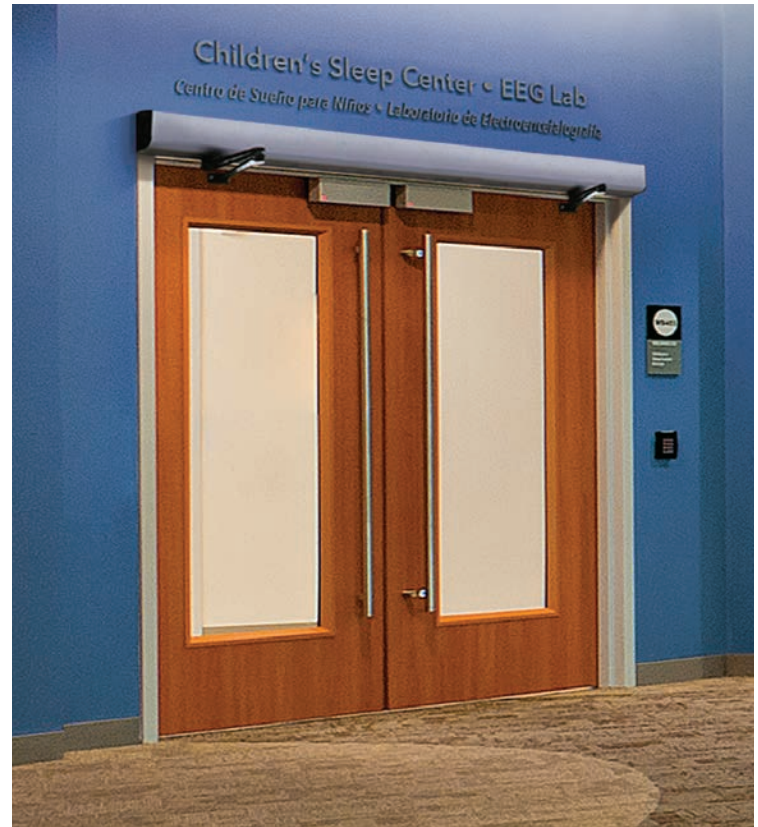

- Latch Retry: if the door does not latch when closing, the SW200i will detect this condition and immediately open the door to 10 degrees and execute two attempts to latch the door.
- On-board timing sequencer
- On-board 12V or 24V transformer
- Low pass filter (i.e. "delay on make")
- Door position relay
- Kill input to close doors immediately
- Self-learning set-up – measures inertia and door weight
- Low Power Consumption (300 watts, 2.5 amp (max))

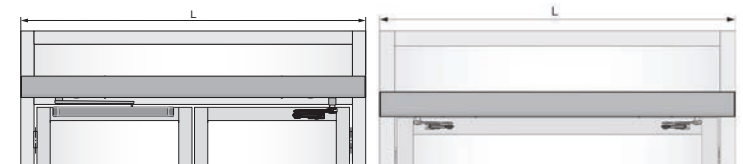

Door Set-ups:

Left: Single

Below Left: Simultaneous Pair

Below Right: Pair Egress

Operation

- Automatic sensor activation (ANSI A156.10)
- Push plate activation (ANSI A156.19 or A156.10)
- Push and go feature allowing door to open automatically when operator senses movement of door (ANSI A156.19)
- Power assist open – provides easy to open push forces (ANSI A156.19)
- Internal, push to open, push to close (i.e., ratchet relay) (ANSI A156.19)
- Speed controlled Extended Closing Torque (ECT) to provide power assist close with on-board functionality to automatically adjust torque without increasing speed
- Loss of Power: the operator controls the door closing, preventing slamming of door
- Torque Limiting: if positive air pressure condition is removed, operator compensates accordingly and will not slam

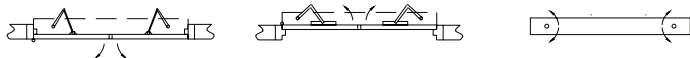

Door Operator Handings

Electric Lock Management

- Lock monitoring prevents operator(s) from opening door(s) until release of electrified lock
- Operator pulls door closed before opening, unjamming electric latch hardware
- Sequenced operation between operators for pairs of doors allowing lock release and astragal coordination
- Electric Lock Output: selectable 12 VDC, maximum 1200 mA / 24 VDC, maximum 600 mA

Sensor Monitoring

- Monitored Door Mounted Presence Sensors – upon detection of sensor failure, the operator will automatically revert to low energy mode
- Blanking Potentiometer: tells sensors on swing side of door when to shut off
- Sensor Recognition – learn process
- Torque Cancellation – Extended Closing Torque (ECT) is deactivated if signal is received from door mounted presence sensors of a possible obstruction

Aesthetics

- Aesthetically pleasing, low profile appearance: 4-5/16" (109mm) high by 5-1/8" (130mm) deep
- Continuous header for full width of door
- Same header/housing as ASSA ABLOY PowerSwing and ASSA ABLOY SW100 for consistent sightlines in your facility
- Finishes: anodized, powder coat, Kynar, clad

Configurations

- Surface Applied
- Overhead Concealed – center pivoted or offset pivoted doors
- Overhead Concealed – with emergency breakaway
- Side Load
- Bottom Load

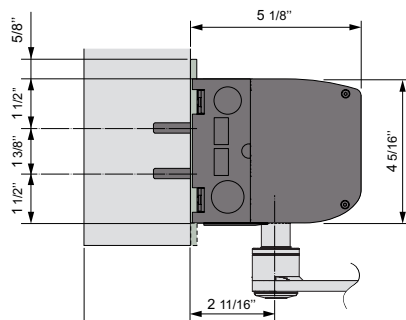

Authorities

- UL/CUL approved
- UL Listed Fire Door Operator
- UL10C, UL325, UL991, UL244A, UL1998, UL1310
- IBC and CBC
- ANSI A156.10 / ANSI A156.19
- CAN/CSA-C22.2 NO 223-M91 and CAN/CSA-C22.2 NO 223-M92
- California State Fire Marshall

Sensor Packages

- Sensor Packages as follows:
 - ANSI A156.19**
 - Activation: push plates per your selection
 - Safety devices: not required per ANSI. Optional door mounted presence sensors (DMPS) are available

ANSI A156.10

- Activation: push plates per your selection (motion sensors or push plates)
- Choice of ASSA ABLOY i-Adapt™ door mounted presence sensor system:
 - A202 – ASSA ABLOY i-Adapt Premium – stand alone, adapted field, door mounted presence sensors (DMPS)
 - A102 – ASSA ABLOY i-Adapt Flex – overhead presence sensor (OPS) and two door mounted presence sensors (DMPS) per leaf (approach and safety)
 - A101 – ASSA ABLOY i-Adapt Flex - overhead presence sensor (OPS) and one door mounted presence sensors (DMPS) per leaf (safety)
 - A100 – ASSA ABLOY i-Adapt Flex – Knowing Act applications – pair egress only – motion sensor approach and safety side for secondary activation per ANSI A156.10

Authorities

Operator type	Electro-mechanical
Door width	36" – 48" (914 – 1219mm)
Door weight	100 – 700 lb (45 – 315 kg)
Power supply	120 V AC +10/-15%, 50/60 hz
Power consumption	Max. 300W
Auxiliary voltage	24 V DC, max. 700 mA
Internal control fuse	2 x T 6, 3 AH 250 V
Electro-mechanical locking device	Selectable: 12V DC, max. 1200 mA / 24 V DC, max. 600 mA
Door opening	Push: 80 – 110° with reveal 0 – 12" (0 – 305mm) Pull: 80 – 110° with reveal 0 – 5-1/8" (0 – 130mm) PAS: 80 – 95° (concealed application)
Opening time (0 – 80°)	Variable between 2 – 12 seconds
Closing time (90 – 100°)	Variable between 4 – 12 seconds
Hold open time	1,5-30 seconds
Ambient temperature	-31° F to 160° F (-35° C to 71° C)
Relative humidity	Max. 85%
Drive weight unit (non-condensing)	19.8 lb (9 kg)
This product is to be installed internally or externally with suitable weather protection.	
Class of protection	IP 20.
Complies with: ANSI/BHMA A156.19, ANSI/BHMA A156.10, UL325, UL 991, UL 244A, UL 1998, UL 1310, UL 10C, CAN/CSA-C22.2 NO 223-M91, CAN/CSA-C22.2 NO 247-92 and CA State Fire Marshall	